

## **AC 2009-129: INTEGRATING ALTERNATIVE-ENERGY TECHNOLOGY INTO ENGINEERING EDUCATION**

### **Linfeng Zhang, University of Bridgeport**

Linfeng Zhang is an assistant professor of Electrical Engineering at University of Bridgeport. His research interests are in sensors and actuators, fuel cells, and photovoltaic cells.

### **Xingguo Xiong, University of Bridgeport**

Xingguo Xiong is an assistant professor of Electrical Engineering at University of Bridgeport. His research interests are in MEMS, nanotechnology, VLSI.

### **Junling Hu, University of Bridgeport**

Junling Hu is an assistant professor of Mechanical Engineering at University of Bridgeport. Her research interests are in computational fluid dynamics.

# **Integrating Alternative Energy Technology into Engineering Education**

# Integrating Alternative Energy Technology into Engineering Education

## Abstract

Alternative Energy Technology attracts more and more attention as evidenced by the tremendous amount of investment from the federal government, automotive industry, and fuel cell /photovoltaic cell manufacturers. To advance the search for solutions to the world's most pressing energy problems and to prepare our future Connecticut workforce for the emerging alternative energy technology field, University of Bridgeport (UB) has provided a graduate level course, Alternative Energy Technology. This course is related to chemistry, electronics, and mechanics and the graduate students are with different engineering background. The challenges in the teaching are addressed and the possible solutions are given in this paper. Moreover, the teaching experience in this course is helpful for the licensure application for a new M.S. program, Sustainable Energy Engineering (SEE) in the school of Engineering at UB.

## 1. Introduction

The world energy demand keeps increasing in recent years due to the rapidly rising living standards and expanding populations. However, the non-renewable energy resource, fossil fuels, is running out and the crude oil supply from Middle East is unstable<sup>1</sup>. Thus, the price of energy dramatically fluctuates. In the same time, the using of fossil fuels causes air pollution and global warming with the accumulation of greenhouse gasses. To meet the energy demand, improve the energy security, and protect the environment, developing alternative or sustainable energy, such as solar, wind, tide, geothermal, biomass energy, is a promising solution.

In U.S., the energy consumption increases around 25% from 1970 to 2008 and the import energy resource increases proportionally due to the constant energy resource production as shown in Figure 1. Electricity from sustainable energy resources (excluding hydropower) have nearly doubled since 2000 as shown in Figure 2 (a). Wind grew 45% and solar (photovoltaic cells) PV grew 40% in 2007 from the previous year as shown in Figure 2 (b). Both of them are the fastest growing renewable energy sectors. However, electricity from sustainable energy resources (excluding hydropower) in 2007 still represents a small percentage of overall installed electricity capacity (3%) and generation (2.5%) in the U.S. as shown in Figure 2 (b).

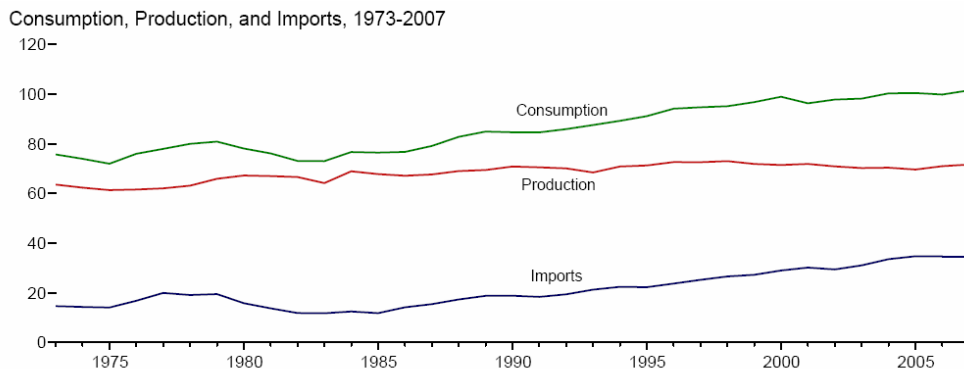
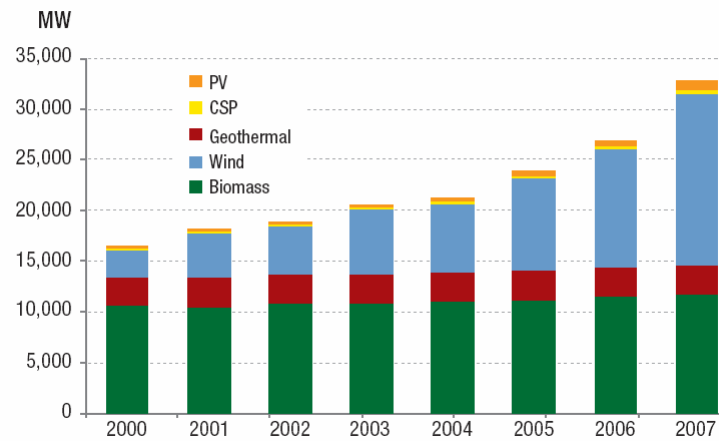
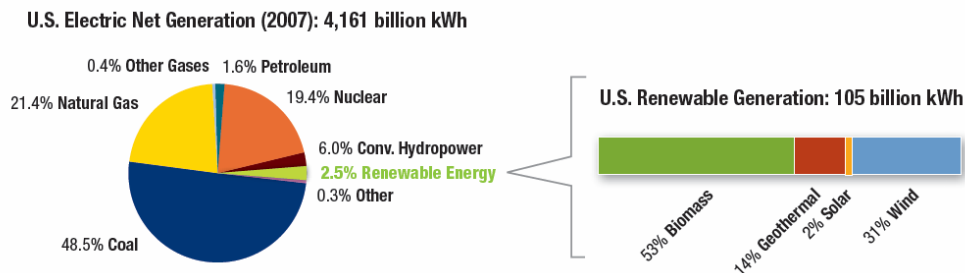

Figure 1 US Primary Energy Overview (Quadrillion Btu)<sup>2</sup>



(a)



(b)

Figure 2 sustainable energy overview (a) and the energy resources distribution in 2007 (b)<sup>3</sup>

To reduce national consumption of energy and to encourage a wide range of alternative energy sources, President Obama voted in favor of the Energy Policy Act of 2005, proposed a New Energy for America plan, and signed American Recovery and Reinvestment Act (ARRA). The key points in these policies are as following:

- Reduce the overall U.S. oil consumption by at least 35%, or 10 million barrels per day, by 2030 in order to offset imports from OPEC nations.
- Help create five million new jobs by strategically investing \$150 billion over the next ten years to catalyze private efforts to build a clean energy future.
- Ensure 10 percent of our electricity comes from renewable sources by 2012, and 25 percent by 2025.
- Implement an economy-wide cap-and-trade program to reduce greenhouse gas emissions 80 percent by 2050<sup>4</sup>.

Based on the above federal policies, U.S Renewable Energy (RE) and Energy Efficiency (EE) industries could generate over 37 million jobs per year by 2030 although RE&EE created only over 9 million jobs in 2007<sup>5</sup>. In order to educate and prepare enough technical and scientific workforce, education in alternative or sustainable energy is more and more important<sup>6</sup>.

## 2. Course: Alternative Energy Technology (AET)

A graduate course, AET, with 3 credits has been provided by the Department of Electrical Engineering at UB in each spring semester for last two years and this course introduces different alternative energy sources including solar, geothermal, wind energy, etc. Due to the interdisciplinary nature of AET, this course has to be designed by the instructor according to the background of the students.

### **Course description**

- Understand the alternative or sustainable energy sources.
- Comprehend the engineering fundamentals of various types of fuel/photovoltaic cell systems.
- Apply the energy system fundamentals and analyses to address the key issues in design and integration of various AET systems.
- Gain knowledge and skills to provide engineering services in planning, designing, and constructing power system with alternative energy sources.

### **Textbook**

There are many books on alternative or sustainable energy but none is designed as a textbook. The instructor has to reorganize the contents from different resources to cover the production and utilization of the alternative energy, such as geothermal, solar, wind, and tide energy. For fuel cell, *Fuel Cell Systems Explained (Second Edition)* by James Larminie and Andrew Dicks is preferred since it includes almost all necessary topics in fuel cells. However, the instructor still needs to add more contents in electrochemistry and thermodynamics for the students without such backgrounds. In the mean time, the instructor also needs to design homework. For photovoltaic cell, *Physics of Solar Cells: From Principles to New Concepts* by Peter Würfel is a good reference book. Similar to the teaching in fuel cells, the instructor needs to add the contents in semiconductor and polymer and design homework.

In addition, journal papers and invited talks to supplement lecture materials work effectively, providing graduate students with the cutting-edge technology and a real world perspective.

### **Course content and teaching schedule**

The course content consists of four parts: introduction of the alternative energy sources, fuel cell, photovoltaic cell, and power delivering. The teaching schedule for the 15-week lecture is as follows:

- 2 weeks: introduction of the alternative energy resources

The alternative energy sources, such as solar, biomass, wind, geothermal energy, and hydro, will be covered. For each energy resource, the power generation and utilization will be discussed as well as the challenges.

- 6 weeks: fuel cell

The following basic knowledge is added at the beginning due to the students' different background:

- The 1<sup>st</sup>, 2<sup>nd</sup>, and 3<sup>rd</sup> laws of thermodynamics
- The terms such as internal energy, work, enthalpy, entropy, Gibbs free energy, specific heat capacity
- The terms such as ideal gas, reversible process, Carnot cycle (heat engine)
- The kinetics of chemical reaction and the effects of temperature, partial pressure on the reaction rate

Then, it is easy for the students to understand the fuel cell system:

- Theoretical calculation of the open circuit voltage
- Fuel cell irreversibilities.
- Proton exchange membrane fuel cell
- Alkaline Electrolyte Fuel Cells
- Direct Methanol Fuel Cells
- Medium and High Temperature Fuel Cells
- Fuelling Fuel Cells

➤ 5 weeks: photovoltaic cell

Similar to the teaching in fuel cell, the following basic knowledge is added for the easy learning of the students with different background:

- Semiconductor, dopants
- Fermi level
- PN junction
- Some terms such as mean free path, depletion region

Then, the following topics will be discussed:

- Photons
- Basic structure of solar cells
- Limitation on energy conversion in solar cells
- Concepts for improving efficiency of solar cells
- Organic solar cells

➤ 2 weeks: power delivering

This part may be difficult to most of the students and it will cover some basic knowledge in power electronics, such as DC Regulation and Voltage Conversion, Inverters, Fuel Cell/PV cell or Capacitor Hybrid Systems

In the teaching of the above contents, discussions in the class are helpful to ensure that students are not overwhelmed by the multidisciplinary material or the course pace, thus they can follow the lecture notes with strong interest. In the mean time, the feedback from the discussion is very helpful to improve the course design, especially in the homework and project design.

### Sustainable Energy Lab

To obtain some hand-on experience, a sustainable energy lab is quite helpful. Currently, hydrogen fuel cells, potentiostat, impedance analyzer are available for the students to measure the characterize the power devices and understand the effects of the operating conditions on the device performance. There are also some PCs with Labview/Matlab and data acquisition boards for the course project design.

### Course project and student contest

There usually are two design projects and the students can integrate their knowledge in alternative energy and in engineering to solve a real problem. The projects are developed on our platform, a new greenhouse, implemented through Matlab Simulink. Here is a general description of this platform:

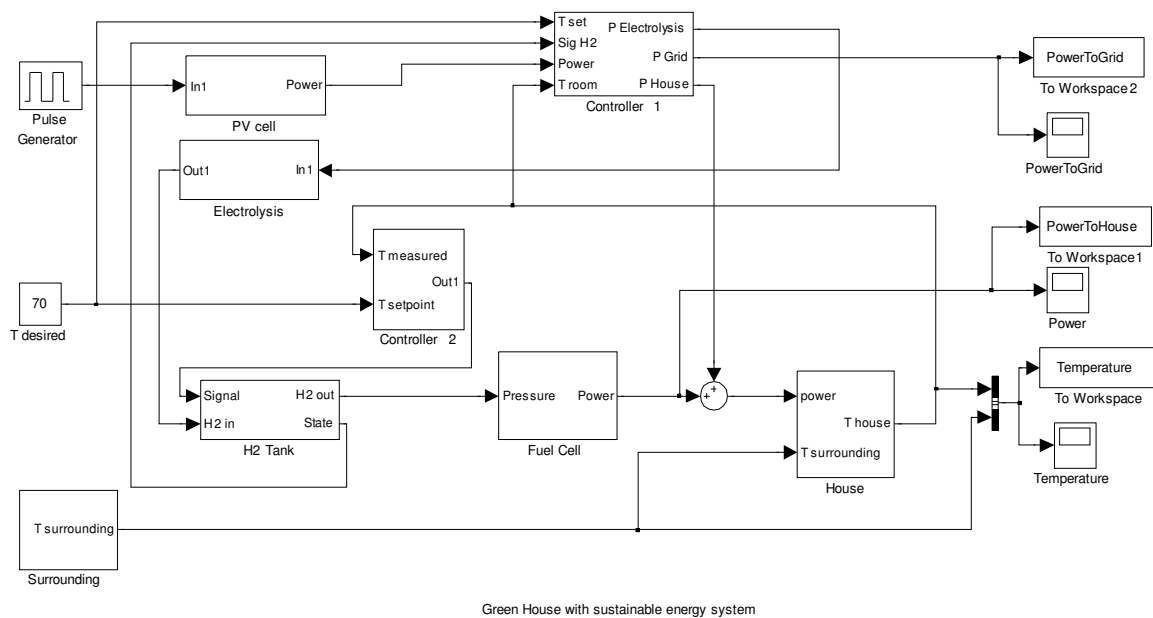

Figure 3 The block diagram of the power system for a green house

*To maintain the greenhouse temperature, power is supplied from a hydrogen fuel cell (FC) system and a photovoltaic (PV) cell system. These two systems are inter-related: some power from the PV system is used to produce hydrogen for the fuel cell system through water electrolysis. Moreover, several nonlinear feedback controllers are used for the process control. The design includes four subsystems: house, fuel cell/PV cell, controllers, and surrounding temperature, as shown in Figure 3.*

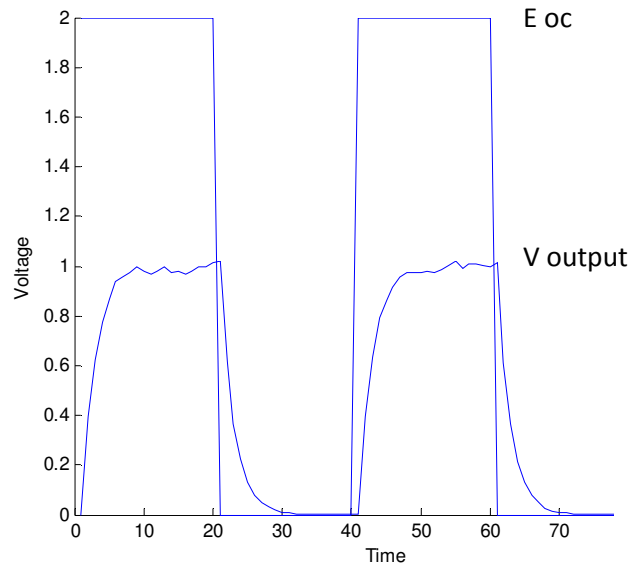

Figure 4 The output voltage from fuel cell system

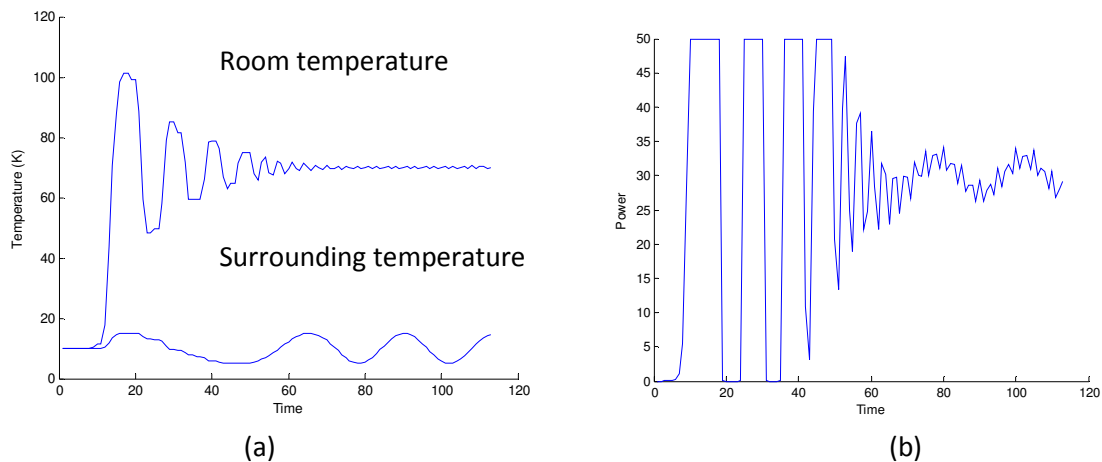

Figure 5 The room temperature and the surrounding temperature (a) vs. time.  
The power supplied from fuel cell system (b) vs. time.

The course projects can be the implementation of one subsystem in the above greenhouse platform. For example, the output voltage of a fuel cell subsystem can be simulated with the consideration of different overvoltages and double charge layer on the surface of the electrodes as shown in Figure 4. Similarly, other energy sources, such as PV cell system, can be simulated as other subsystems. Finally, the whole power system of a green house can be simulated and the preliminary results are shown in Figure 5. In the future, an optimal design for the best performance/cost ratio will be investigated with the commercial FC and PV cell systems.



Figure 6 The design of the student center

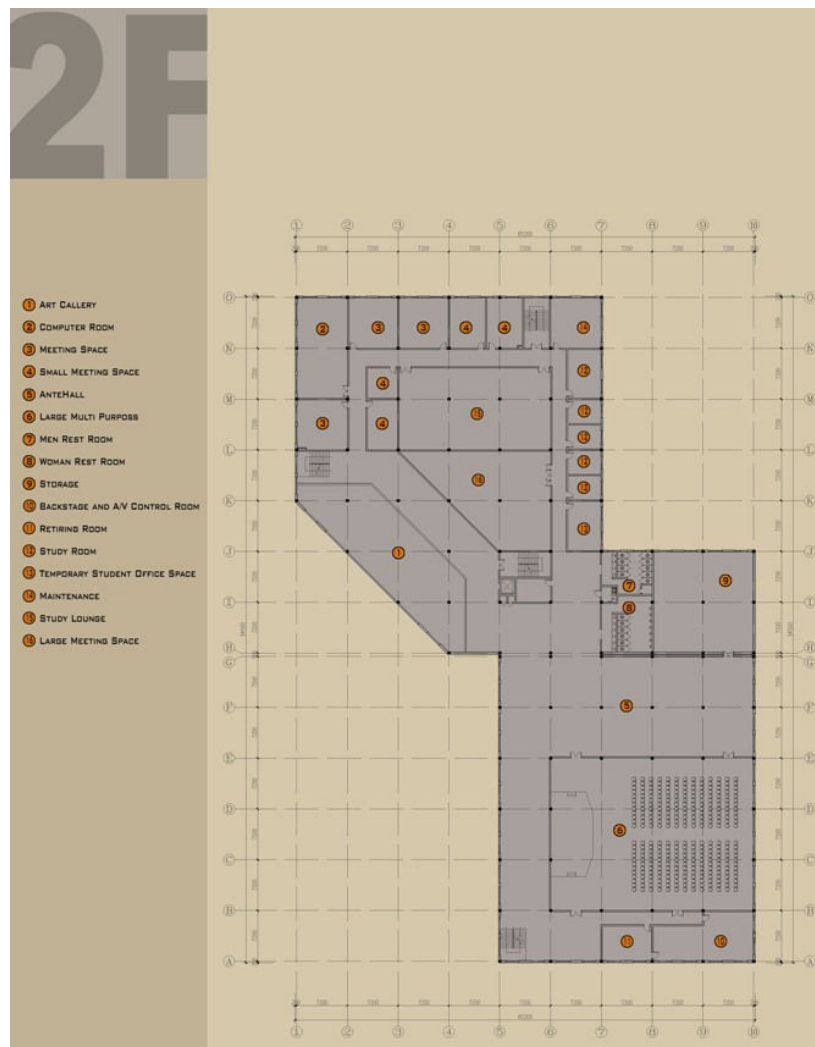

Figure 7 Floor plan on the 1<sup>st</sup> floor

Besides the above course projects, students are encouraged to participate the annual hydrogen student design contest sponsored by National Hydrogen Association<sup>7</sup>. For example, the project of the contest in 2008 is:

*Imagine your team has \$28 Million USD to design a new green Student Center powered by hydrogen for the State University of New York – Farmingdale Campus on Long Island, NY. Teams are challenged to design an energy efficient building that utilizes hydrogen produced from renewable sources for as much of its energy needs as feasible. Although your design should aim to address the needs of SUNY-Farmingdale, a great design will have key elements that are applicable to other buildings around the world. The hydrogen technologies and systems you select for your project plan must be commercially available and possible to implement for practical, real-world use by June 2009.*

Three students in the class formed a team to design the whole building and power system as shown in Figure 6 and Figure 7. Furthermore, they also analyzed issues in safety, cost, and environment. Through this design, especially through the cost analysis in Table 1, the building construction is regarded as the most expensive part and the cost of PV cells, fuel cells, and hydrogen storage is significant in the power system. Thus, the challenges in a real implementation of a building with alternative energy sources are quite straightforward.

Table 1 Cost

| SN | Product description                                | Quantity | Unit cost   | Total cost |
|----|--|----------|-------------|------------|
| 1  | Civil works  | 1        | 2236900     | 2236900    |
| 2  | PV Cell plus Installation(ES-A Series)             | 1        | 2373060     | 2373060    |
| 3  | Electrolyzer(Hogen H series)                       | 12       | 140000      | 1680000    |
| 4  | Hydrogen Generator(Nedstack PS 100)                | 4        | 225000      | 900000     |
| 5  | Deionizer(Purelab S7)                              | 2        | 7000        | 14000      |
| 6  | Compressor(PDC-3-600/3000)                         | 2        | 58000       | 116000     |
| 7  | Storage (CPI Seamless )                            | 2        | 70000       | 140000     |
| 8  | Demolition and moving charges                      |          | 50/sq ft    | 1470000    |
| 9  | Education plan                                     |          |             | 200000     |
| 11 | Marketing plan                                     |          |             | 500000     |
| 12 | Electricals and Plumbing works                     |          | \$40/sq ft  | 1176000    |
| 13 | Overall storage, moving, installations(Insurances) |          |             | 200000     |
| 14 | Heat Exchanger                                     | 2        | 100000      | 200000     |
| 15 | Inverter   | 2        | 284724      | 569448     |
| 16 | Insurance  |          |             | 1000000    |
| 17 | Electrical sub contractor overhead                 |          | \$100/sq ft | 2940000    |
| 18 | Mechanical subcontractor overhead                  |          | \$100/sq ft | 2940000    |
| 19 | Civil subcontractor overhead                       |          | \$100/sq ft | 2940000    |
|    | Total Cost   |          |             | 21595408   |

## Outcome and assessment

The following is the list of outcomes from the course:

- Explain different alternative energy sources
- Theoretically simulate the performance of fuel cell and PV cell
- Test and analyze the performance of the fuel cell
- Design the power system with alternative or sustainable energy

The assessment methods consist of homework, exams, and projects. The homework and projects cover 40% of the total grade and the exams cover the rest.

### 3. Education in alternative or sustainable energy

It is more obvious that the knowledge in alternative or sustainable energy is essential to the engineering students and the nationwide demand for well-qualified professionals in the alternative energy rapidly increases. However, there are only two U.S. universities providing independent graduate programs in this area and neither of them is in Connecticut. In order to prepare the technical and scientific workforce in this field, the School of Engineering at UB is preparing the licensure application material for M.S. Sustainable Energy Engineering program. The Sustainable Energy Engineering degree certifies that knowledge has been gained in the Sustainable Energy Engineering discipline. Graduates will combine knowledge of energy with engineering principles to produce solutions and innovations in sustainable energy generation and utilization. In addition, program graduates will have critical thinking skills for producing scholarship in the SEE area, showing enterprise in engineering work, and communicating with proficiency about issues related to the SEE area.

Table 2 is the structure of the curriculum and this curriculum ensures that graduating students have breadth in SEE-related disciplines and depth in one of two tracks. Students take two required courses (Advanced Mathematics and Solid State Electronic Devices) to acquire knowledge of fundamental scientific and engineering principles. The program has two tracks as shown in Table 3: (i) Sustainable Energy Generation, (ii) Sustainable Energy Utilization. Students take at least four courses in one of the tracks to acquire depth in that area. A plan of work from each student should be approved in the first semester.

In the M.S. program, a Master student must complete 30 credits hours of graduate level (500-level) course work, including a master project or a thesis. The structure of the curriculum is shown in Table 2 with the following requirements in the study:

- Successfully complete Advanced Mathematics and Solid State Electronic Devices;
- Successfully complete Thermodynamics, Applied Electrochemistry for the Sustainable Energy Generation track;
- Successfully complete at least three courses in one SEE track;
- Successfully complete at least one courses in another SEE track;
- Successfully complete a project (3 credit hours) or complete and successfully defend a thesis (6 credit hours).

Table 2 The structure of the curriculum

|                               |                                |
|-------------------------------|--------------------------------|
| Basics                        |                                |
| Sustainable energy generation | Sustainable energy utilization |
| Project or Thesis             |                                |

Table 3 List of representative courses

|                          |
|--------------------------|
| <b>Basics</b>            |
| Advanced Mathematics     |
| Thermodynamics           |
| Applied Electrochemistry |
| Semiconductor            |

| <b>Sustainable energy generation track</b>  | <b>Sustainable energy utilization track</b> |
|---|---|
| Alternative (Sustainable) Energy Technology | Hybrid System Fundamentals                  |
| Fundamentals of Photovoltaic Cell           | Electrical Power System                     |
| Sustainable Energy Lab                      | Power Electronics                           |
| Biofuel                                     | Power Electronics Lab                       |
| Nuclear power                               | Mass and Heat Transfer                      |
| Micro-power source                          | System Integration and Optimization         |
|   | Advanced Controls                           |
|   | Energy Storage                              |

Besides the education, the SEE master's degree program will create opportunities for faculty-student research and grant-seeking. Recognizing the importance of sustainable energy, the NSF and DOE will be the most important funding sources. These efforts will be supported by additional faculty in SEE, expanded physical space, and student enrollment in the program. The licensure application for this program will take around one and half year and this program will start in Spring, 2010.

#### 4. Conclusions

This paper discussed the design and implementation of the graduate course, Alternative Energy Technology, in the Department of Electrical Engineering at University of Bridgeport. The paper provides the contents of the course in details: topics, references, and projects. The experience presented is quite helpful for the licensure application for M.S. SEE program. The results of the course are encouraging and the feedback from the students is analyzed to improve the teaching.

#### Bibliography

1. Sarma Pisupati, Curriculum Development for a New Energy Engineering Major at The Pennsylvania State University. in ASEE Annual Conference. 2008.
2. [http://www.eia.doe.gov/emeu/mer/pdf/pages/sec1\\_2.pdf](http://www.eia.doe.gov/emeu/mer/pdf/pages/sec1_2.pdf).
3. [http://www1.eere.energy.gov/maps\\_data/pdfs/eere\\_databook\\_091208.pdf](http://www1.eere.energy.gov/maps_data/pdfs/eere_databook_091208.pdf).
4. <http://my.barackobama.com/>.
5. Defining, Estimating and Forecasting the Renewable Energy and Energy Efficiency Industries in the U.S. and in Colorado, the American Solar Energy Society and Management Information Services Inc.
6. Craig Somerton , Developing a design based alternative energy course. in ASEE Annual Conference. 2006.

7. <http://www.hydrogenassociation.org/>.